



LASER MICROMETER 2008

INSTALLATION & OPERATING MANUAL

Read this Manual thoroughly before installation and operating the instrument. After reading carefully, retain it close at hand for future reference needs.

1. WARNINGS



VISIBLE LASER RADIATION !
DO NOT ATTEMPT TO SERVICE THIS
DEVICE DUE TO THE POSSIBILITY
OF
EYE DAMAGE.



INSIDE HIGH VOLTAGE !
DO NOT ATTEMPT TO OPEN COVER OF THIS
DEVICE DUE TO THE POSSIBILITY OF ELECTRICAL
DAMAGE TO HUMAN BODY.



DO NOT DROP !
HANDLE WITH CARE.

2. WARRANTY

If malfunction under normal use within 2 years from the date of purchase, it will be repaired or replaced, at our options, free of charge. Contact your dealer or nearest representative for more information.

However, the following damages may be subject to repair charge even if damage occurs within the warranty period.

1. Unit malfunction or damage if user open the cover of device, unauthorized persons repair.
2. Usage of without electrical ground connection.
3. Unit malfunction or damage due to result of moving, dropping or transportation after purchase.
4. Unit malfunction or damage due to fire, gas, salt, natural disaster, abnormal high voltage input to the device.
5. Unit malfunction or damage due to outside use of device, water or similar liquid pouring on the device or sinking inside water or similar liquids.
6. This device has been produced for a dimension or diameter measurement. It can be used in a factory or laboratory environment. It can not be used other than intended aim.

This warranty is not transferable and is only valid within the country of the original purchase made.

Table of Contents

1. Warnings	2
2. Warranty	3
3. Introduction	5
4. Installation	8
5. Parameters	10
6. Operation	12
7. Inspection and Maintenance	14
8. Communication	15

3. INTRODUCTION

The Laser Micrometer is a high-precision *non-contact* laser dimensional measurement systems.

With non-contact measurement capability, this system has some advantage over conventional measuring systems during measuring soft, elastic or hot materials, such as extrusion of electrical cable, pipe, tube etc. Using of non-contact laser micrometer, you get some benefits such as accurate control, better quality and save raw materials.

There is no maintenance needs inside the device by user. Do not try to open the cover of device.

It use 1 mW, 655nm Laser Module with very fast scanning method. To be able to get best result from it, lenses should be clean, measured object should be in the center of measuring zone and parameters should be set according to the needs.



A SAMPLE APPLICATION of NON-CONTACT LASER MICROMETER at CABLE PRODUCTION LINE

TECHNICAL SPECIFICATION

Measurement Range	0.5 - 40mm
Gate size	50mm
Scan velocity	70m/s
Resolution	1 μm
Repeatability *	$\pm 1 \mu$m
Accuracy *	$\pm 2 \mu$m or ± 0.3 of reading value
Scan Rate	416 Scan/s
Operating temperature	0-45° C
Relative Humidity	0-95% non-condensing
Power supply	85Vac to 285Vac
Dimension (L x W x D)	384 x 150 x 84mm
Power consumption	Less than 10 Watt
Outputs / Inputs :	<p>Communication: MODBUS RTU 9600-19200 BAUD RATE RS485 and RS232</p> <p>Analogue: 0-10Volt dc</p> <p>Motorized Potentiometer Control Output: +/- 5Volt; by changing the polarity</p> <p>Relay Output: (NO) Dry Contact for Alarm</p> <p>Pulse Input: Encoder input for Speed and Length Measurement</p>

*At the center



Fig.1

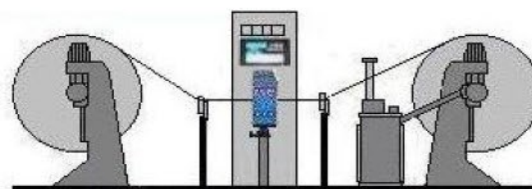
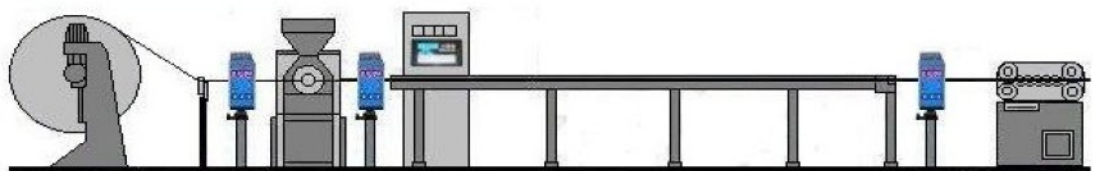
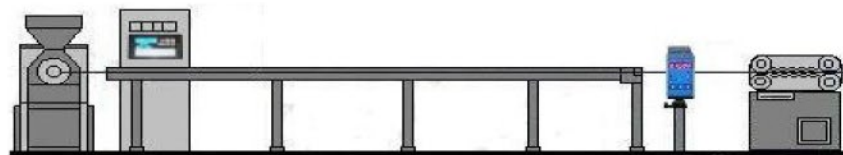
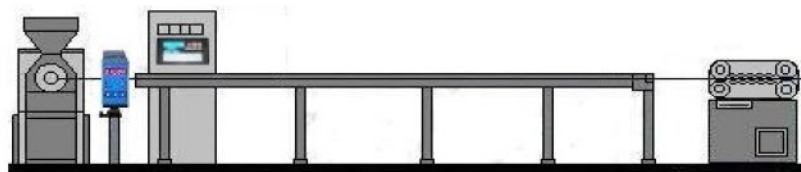

Fig. 2

4. INSTALLATION

You may need followings to be able to installation :

- 1- Laser Micrometer
- 2- 2 pcs Metric 6mm screws and washers (To be able to fix on a stand)
- 2- 220Volt Power Cord
- 3- A stand
- 4- Alarm and 2 Pins female Mike-Connector (If it is needed)
- 5- Motorized Potentiometer and 4 pins female Mike-Connector (It depends on configuration)
- 6- 4 Pins female Mike-Connector for Analog Output 0-10Volt (It depends on configuration)
- 7- 9 Pins male D-Sub Connector for RS485 or RS232 Communication (It depends on configuration)
- 8- 3 Pins female Mike-Connector and Encoder, For Speed and Length measurement (It depends on configuration)



You may use and do the one or a few of the following configuration to be able to make auto-control of the extruded product.

1- If your system has PLC, computer or similar system: By using RS485 or RS232 MODBUS RTU connection and getting reading value and doing automation and recording reading values etc.

2- If your system has Analogue input to a PLC or similar system: Making Analogue output connection and doing automation from your system.

3- If your system has potentiometer for motor driver, we have motorized potentiometer (10Kohm). You just replace it with our Motorized Potentiometer and when you do

the needed setup of parameters accordingly and press  button, the Laser Micrometer

will do auto-control of the puller (or extruder) accordingly. This auto-control method is the easiest one if you do not have Automation facilities such as PLC, HMI etc.

4- Observing from displayed reading value and doing needed action by an operator. You may also use alarm output to be able to get warning in case of reading values outside of the Upper and Lower Limits.

- By using 2 screws and 2 washers, fasten the laser micrometer on the stand.
- Plug the Power Cord in the power inlet of the laser micrometer.
- Insert and fasten Mike connector (2 pins connector) of the Alarm to the laser micrometer.(if you will use it)
- Insert and fasten Mike connector (4 pins connector) of the Motorized Potentiometer cable or for Analogue Output.(if you will use it)
- Do RS485 or RS232 connection of communication. (if you will use it)



Analogue Output
 pin2: 0 - 10 volt output
 pin3: 0 volt
 pin1 and pin4 : to Motorized Potentiometer





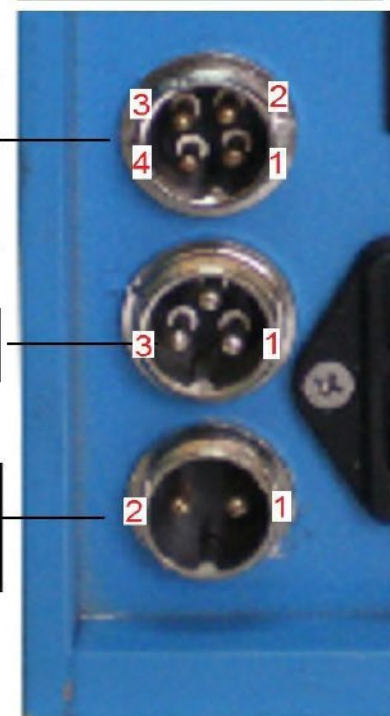

pin3 : Encoder PULS
 pin 1 : Encoder 0 volt













pin1 and pin2 : Normally Open Dry Relay Output for Alarm



5. PARAMETERS

Parameters in the Laser Micrometer 2008 are as follow:

	dIA	Diameter : Desired Diameter Set Value
	UP L	Upper Limit (just for Alarm) : It must be over than Diameter Set Value(dIA). When the measured value is bigger than Upper Limit Set Value, Alarm Output Contact will be ON to warn the operator(if alarm connected). Example: dIA = 05.150 UP L = 05.300
	Lo L	Lower Limit (just for Alarm) : It must be lower than Diameter Set Value(dIA). When the measured value is lower than Lower Limit Set Value, Alarm Output Contact will be ON to warn the operator(if alarm connected). Example: dIA = 05.150 Lo L = 05.000
	toL	Tolerance : It is Diameter Value's upper and lower tolerance value. toL value can not be lower than 1. If the measured value is inside the (dIA + toL) and (dIA - toL) values, the speed of the motor will not be changed (there will be not movement at the motorized potentiometer). It means that measured value is acceptable. If the measured value is outside the (dIA + toL) and (dIA - toL) values, the speed of the motor will be changed proportionally (there will be movement at the motorized potentiometer) Following examples are just sample set values. Example 1: for dIA :01.000 => toL :00.002 can be reasonable Example 1: for dIA :05.000 => toL :00.010 can be reasonable Example 1: for dIA :10.000 => toL :00.020 can be reasonable
	A	Averaging Number : <i>Laser Diameter 2008</i> does 416 diameter measurement in a second. If averaging number is 00100, every averaging value will be shown in 0.24 seconds intervals. If averaging value number is 00200, averaging value will be shown in 0.48 seconds intervals. This value can not be below 100. Therefore, last 2 columns shapes are like "00" and unchangeable. If A value is to high, averaging value is seen delayed and in automatic control, it will control the motorized potentiometer in each delayed intervals. 00200 Averaging value appropriates in many cases if <i>Laser Diameter 2003</i> is installed just after the extruder and before cooling trough. But if <i>Laser Diameter 2008</i> is installed after the water cooling trough, averaging value has to be enough to be able to make delay in the speed control. It takes time for the extruded product to reach to the <i>Laser Diameter 2008</i> . You must calculate A according to the speed of the line and length of the line.
		IT IS NOT A PARAMETER. Press  button to be able to go further parameters.

	AnALo	<p>Analogue output value(0 – 10 Volt): Analogue output set value. Pin # 2 and 3 of the 4-pin Mike-connector are for analogue outputs. You can set this value for maximum 10 volt. Output is between 0 to 10 Vdc according the set value and measured diameter value.</p> <p>If AnALo = 20.000 , and diameter reading of 20.000 will output 10.000 Volt diameter reading of 10.000 will output 05.000 Volt diameter reading of 00.000 will output 00.000 Volt</p>
	PULS	<p>Encoder Puls Length : Encoder square wave signal each puls length in cm.</p> <p>Example : If Encoder 100 pulse and circumference of the wheel is 40cm . 40/100=0.4 and value is PULS: 00.400</p>
	Cntrl	<p>Control Value: It indicates how much motorized potentiometer will response in case of differences between dIA set value and reading . If this Cntrlvalue is big, motorized potentiometer movement also will be big. You can set this value from 1 to 30. In most case, Cntrl =10 is good enough.</p>
	SP	<p>Skip :This parameter is used when the laser micrometer is installed away from extruder equipment(like after cooling pool. In this situation, there will be distance between Extruder and the Laser Micrometer and naturally there will be delay until diameter change of product to reach to the laser micrometer reading zone because of distance between extruder and the Laser Micrometer. If SP parameter is ON and after the any speed change laser micrometer will be not do any speed change at the next reading . Because, any done speed change will take certain time to reach the laser micrometer reading zone. Keep SP = OFF if <i>Laser Micrometer 2008</i> is used just after the extruder and before cooling trough (it means very close to the extruder)</p>
	PArTY	<p>Parity: It is a communication parameter.</p> <p> No Parity. Use 2 STOP bits at the MASTER side.</p> <p> Odd Parity. Use 1 STOP bit at the MASTER side.</p> <p> EvenParity. Use 1 STOP bit at the MASTER side.</p>
	bAud	<p>Baud Rate: It is a communication parameter.</p> <p></p> <p></p>
	AdrES	<p>Adres: It is a communication parameter. It can be input as slave address from 1 to 247.</p>

6. OPERATION

When you turn on the *Laser Diameter 2008*. The display shows in sequence as below.





Using ways of the laser micrometer for Auto-Correction of diameter of product :

- 1- By using RS485 or RS232 *MODBUS RTU* communication protocol with a PLC, HMI etc. Auto-correction(automation) of diameter or measurement can be done by PLC, HMI etc.
- 2- By using analogue output to such as analogue input of a PLC, etc. Auto-correction(automation) of diameter or measurement can be done by PLC, HMI etc.
- 3- By using our Motorized Potentiometer. If your extruder or puller has potentiometer to control speed, you replace it with our Motorized potentiometer. Auto-correction of the diameter of product will be done with motorized potentiometer.
- 4- By observing the display measurement and operator do the needed adjustment by manually.

Inputting the Parameters :

1- When laser micrometer on, press  button. You will see diameter (**dIA**) parameter on the display.

2- By pressing  or  buttons, you will change the parameters on the display.

3- When you want to change or see the value of the parameter when it is on the display press



button and you will see the last updated value on the display.

4- Flashing digit on the display can be decreased or increased by pressing



or



buttons.

5- To be able to pass next, digit press  button. After last digit it turns to the parameter back.

6- After you do all the needed changes in the parameters, press  button and you will turn back to the measurement

Center Adjustment:

When you operate the *Laser Micrometer 2008*, it is better if you center the measured product vertically and horizontally to be able to get best result. Always try to keep the product near the center position.

If you press *Up Key*  at the measuring state, the display will indicate location of the object vertically. If there is not object at the reading zone, you will see 5 dash line on the display. If there is an object at the reading zone, you will see 2 dash line and 3 digit value. This value just indicate vertically position of the object.

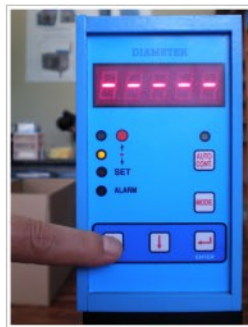

Almost at the Center



This display shows that object is too much at up position .



This display shows that object is too much at down position.



Between - -000 to - - 010 can be acceptable for good measurement.

After you have done centering control, press  button again and you will turn back to the measurement.

Auto Control button :

When the laser micrometer at the measuring mode and if our Motorized Potentiometer and/or alarm installed , the auto-correction and alarm will be in active after you press  button.

To be able to de-activate the function press  button again.

7. INSPECTION and MAINTENANCE

ERRORS:



Lo L is higher than *dIA*



UP L is lower than *dIA*



toL is zero. It must be 1 or more.



- There are more than one object at the reading zone
- Some part of object is outside of reading zone
- Lenses are dirty

CLEANING LENSES:

There are magnets to hold the black cover front of the lens. Also, there are pneumatic air inlet at the black covers. If your environment is dusty or smoky, use the clean air to keep the lenses clean.

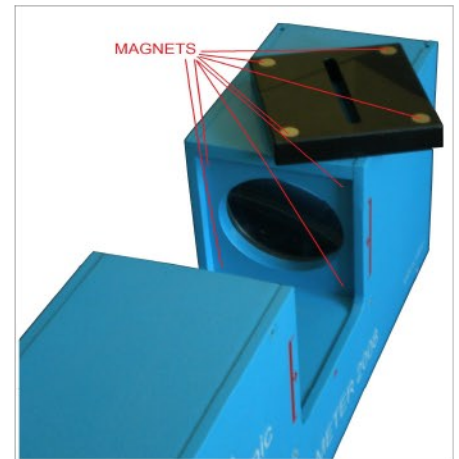

You have to clean lenses in periodic intervals. For cleaning, use cleaning tissue and alcohol. Wet the tissue with alcohol and clean lens, later dry with non-wet another tissue.



FUSE:

If your Laser *Micrometer 2008* is not turn-on, there is fuse holder at the power inlet(see [Fig. 2](#)) It is for protection. Check it. if it is blow up, change with spare one.

8. COMMUNICATION

MODBUS RTU RS485 and RS232 9-pin Female D-SUB connections are as below.

1- **RS485 MODBUS RTU** : (use suitable *RS485 communication Cable*)

- Suitable for long distance and electrically noisy environment.

2- **RS232 MODBUS RTU** :

- for short distance communication.

9-pin D-SUB Pin outs

PIN #	RS485 Modbus RTU	RS232 Modbus RTU
1		
2		TXD
3		RXD
4		
5		Common
6	Common	
7	+5Volt	
8	B+	
9	A+	

Female
9-pin D-SUB
Connector

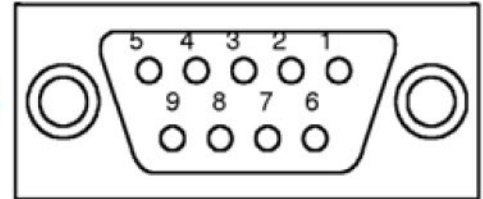

A MODBUS solution over serial line should implement a "2-Wire" electrical interface in accordance with EIA/TIA-485 standard. On such a 2W-bus, at any time one driver only has the right for transmitting. In fact a third conductor must also interconnect all the devices of the bus : the common. Each Slave Device must have unique address ranging from 1 to 247.

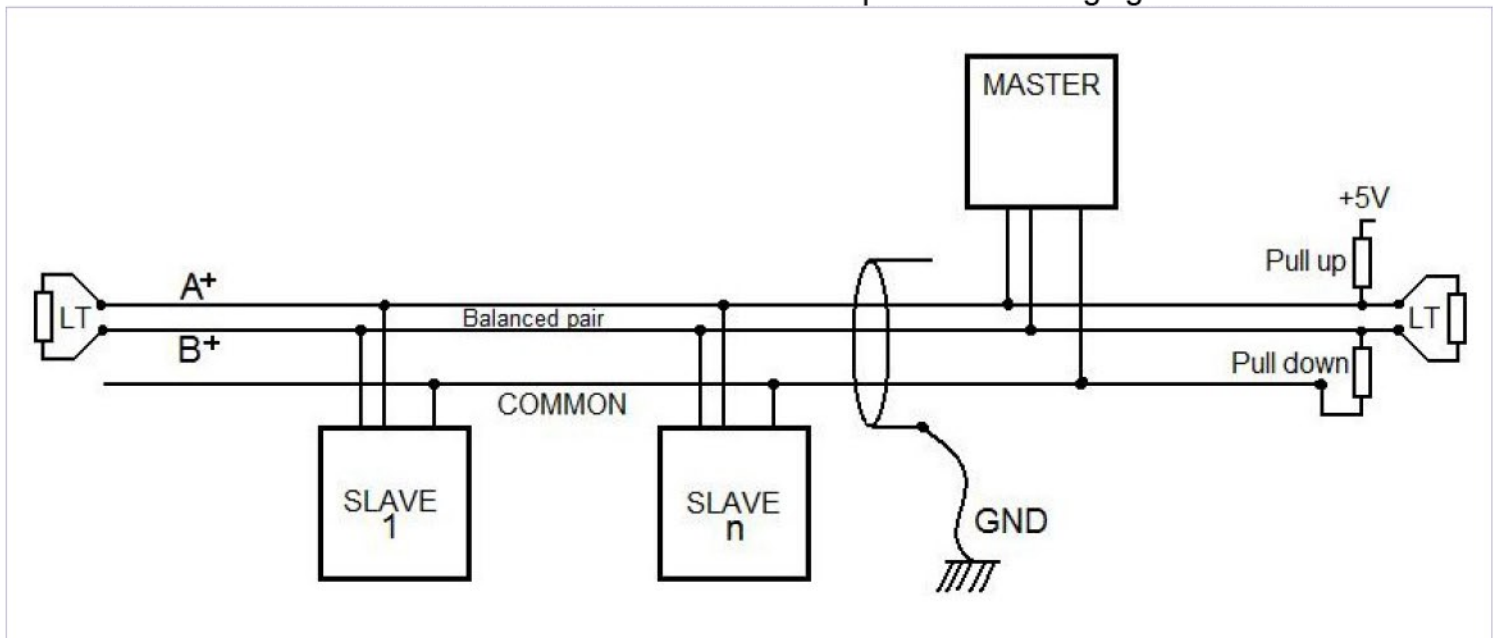

A figure of **32 devices** is always authorized on any RS485-MODBUS system without repeater. The « Common » circuit (Signal and optional Power Supply Common) must be connected directly to protective ground, preferably at **one point only** for the entire bus. Generally this point is to choose on the master device or on its Tap.

A reflection in a transmission line is the result of an impedance discontinuity that a traveling wave sees as it propagates down the line. To minimize the reflections from the end of the RS485-cable it is required to place a Line Termination **near each of the 2 Ends** of the Bus. It is important that the line be terminated at **both** ends since the propagation is bi-directional, but it is not allowed to place more than 2 LT on one passive A+ - B+ balanced pair . Never place any LT on a derivation cable. Each line termination must be connected between the two conductors of the balanced line : A+ and B+. Line termination may be a 150 ohms value (0.5 W) resistor. A serial capacitor (1 nF, 10 V minimum) with a 120 Ohms (0.25 W) resistor is a better choice when a polarization of the pair must be implemented. If one or several devices need polarization, **one** pair of resistors must be connected on the RS-485 balanced pair :

- a Pull-Up Resistor to a 5V Voltage on A+ circuit,
- a Pull-Down Resistor to the common circuit on B+ circuit.

The value of those resistors must be between 450 Ohms and 650 Ohms. 650 Ohms resistors value may allow a higher number of devices on the serial line bus. In this case, a polarization of the pair must be implemented **at one location for the whole Serial Bus**. Generally this point is to choose on the master device or on its Tap. Other devices must not implement any polarization. The maximum number of devices authorized on such a MODBUS Serial Line is reduced by 4 from a MODBUS without polarization.

BOYUT TECHNIC LTD LASER MICROMETER 2008
MODBUS PROTOCOL HOLDING REGISTERS ADDRESS MAP

LASER MICROMETER PARAMETERS	Address	R/W	BYTES
DIAMETER (Set)(unsigned int)	0x01h (1d)	R/W	2Byte
UPPER LIMIT(unsigned int)	0x02h (2d)	R/W	2Byte
LOWER LIMIT(unsigned int)	0x03h (3d)	R/W	2Byte
TOLERANCE(unsigned int)	0x04h (4d)	R/W	2Byte
AVARAGE(unsigned int)	0x05h (5d)	R/W	2Byte
ANALOGUE(unsigned int)	0x06h (6d)	R/W	2Byte
PULS_LENIGHT (unsigned int)	0x07h (7d)	R/W	2Byte
CONTROL	0x08h (8d)	R/W	2Byte
SKIP 1Bits (bit0) 0 = OFF 1 = ON	0X09h (9d)		
PARTY 2Bits (bit1 - 0) 00 = NO PARITY* 01 = ODD PARITY 10 = EVEN PARITY	0X0Ah (10d)	R/W	2Byte
BAUD RATE 1Bits (bit0) 0 = 9600 BAUD RATE 1 = 19200 BAUD RATE	0X0Bh (11d)		2Byte
8Bits (bit7 - 0) MODBUS ADDRESS (from 1 to 247)	0x0Ch (12d)	R/W	2Byte
LENGHT (Measured / RESET) ** (unsigned int)	0x0Dh (13d)	R/W	2Byte
VELOCITY (Measured) ** (unsigned int)	0x0Eh (14d)	R	2Byte
DIAMETER (Measured)(unsigned int)	0x0Fh (15d)	R	2Byte
CENTER POSITION (Measured)(signed int)	0x10h (16d)	R	2Byte

*if you set NO PARITY , use **2 STOP bits**.

* **if encoder connected.

KNOWN FUNCTION CODES

DECIMAL	HEXADECIMAL
03	0x03
04	0x04
06	0x06
16	0x10

PARAMETER LIST

1	dIA
2	UP L
3	Lo L
4	toL
5	A
	OtHEr (Not a Parameter)

6	1- AnALo
7	2- PULS
8	3- CntrL
9	4- SP
10	5- PArty
11	6- BAUD
12	7- AdrES